

# RV generator set Quiet Gasoline™ Series RV QG 7000



## Cummins Onan

Performance you rely on.™



### Features and benefits

- Quietest generator set in its class.
- Exceptionally low vibration levels.
- Integrated design with enclosed muffler for easy installation.
- Self-diagnostic capability to simplify troubleshooting.
- Runs two air conditioners with power to spare.
- Digital voltage regulation for stability as appliance loads change.
- 3-year limited warranty, lifetime drive warranty.
- Gasoline or LP fueled.

### Weight, size and sound level

Weight	290 lbs	(132 kg)
Length	33.6 in	(853 mm)
Width	22.2 in	(563 mm)
Height	16.7 in	(425 mm)
Sound	67 dB(A)	Readings at 10 ft (3 m) half load

- Meets National Park Service sound level requirements (60 dB(A) @ 50 ft) for national park use.  
- Typical installation will further reduce sound level.

### Models and ratings

Model	Fuel	Hz	RPM	Watts	Voltage	Amps	Phase	Circuit breaker
7 HGJAB-1036	Gasoline	60	2880	7000	120	58.3	1	(1) 30 A, (1) 20 A HACR
7 HGJAB-900	Gasoline	60	2880	7000	120	58.3	1	(2) 30 A
7 HGJAB-6756*	Gasoline	60	2880	7000	120	58.3	1	(2) 30 A
6.5 HGJAB-1272	LP vapor	60	2880	6500	120	54.2	1	(1) 30 A, (1) 20 A HACR
6.5 HGJAB-904	LP vapor	60	2880	6500	120	54.2	1	(2) 30 A

Ambient conditions for rated power output with muffler and RV enclosure, per ISO 8528-1:

- Temperature: 77° F (25° C)
- Altitude: 500 ft (152.4 m), (99 kPa dry)

Typical power output change based on ambient conditions:

- Temperature: Power output decreases 1% for every 10° F (5.5° C) increase
- Altitude: Power output decreases 3.5% for every 1000 ft (305 m) increase

Ratings represent minimums. Actual performance may be significantly higher based on installation and operating conditions.

\* Evaporative spec: Effective January 1, 2011, gasoline generator sets on trailers, diesel chassis or any other non-motorized mobile apparatus must have an EVAP generator set, approved tank, EVAP canister, hoses and fittings all meeting the CARB Tier 3 and EPA phase 3 standards and specifications. This law applies in all 50 states.

### Operating temperature range

	Low	High
Gasoline	-20° F (-29° C)	120° F (49° C)
LP	0° F (-18° C)	120° F (49° C)

- Depends upon LP tank capacity, surface area and butane content of LPG.

### Standard features

### Engine details

- Mechanical governor adjustable from service side
- Cummins Onan OHV engine
- Pressurized Thru Flow cooling system
- 4-point focalized mounting system with vibration isolators
- Universal mounting tray with structural capability to support the generator set in RV applications
- Integral USDA Forest Service-approved spark-arrestor muffler
- Replaceable dry element air cleaner
- Integral control box
- Instant one-touch stop switch
- Electronic ignition
- Automatic choke
- Fuel filter
- Electric fuel pump (gasoline), electric fuel solenoid (LPG)
- Positive fuel shutoff (3 psi)
- Enclosed muffler
- Sound-attenuated housing
- Remote waterproof connector
- Spin-on, full-flow oil filter
- Low oil pressure protection
- Over/under speed protection
- Overcurrent protectors (see Models and ratings section)
- Low power factor field overcurrent protection
- 120 in (3 m) generator set output leads
- Digital voltage regulation

Model: Cummins Onan OHV EH65V gasoline engine  
 Design: 4-cycle, OHV, 90 degrees V-Twin  
 Compression ratio: 8:1  
 Displacement: 39.8 in<sup>3</sup> (653 cm<sup>3</sup>)  
 Maximum power: Gasoline-fueled models: 14.0 bhp (10.5 kW), LP-fueled models: 11.6 bhp (8.6 kW)  
 Cooling: Centrifugal blower, generator set mounted for high effectiveness, pressurized system, vertical flow  
 Cooling air volume: Air flow includes engine, generator set control cooling air flow  
 60 Hz at 500 ft<sup>3</sup>/min (14.2 m<sup>3</sup>/min)  
 50 Hz at 417 ft<sup>3</sup>/min (11.8 m<sup>3</sup>/min)  
 Fuel system: Replaceable dry element air cleaner  
 - (Gasoline) side-draft carburetor  
 - Electronic fuel pump with positive fuel shutoff (3 psi), fuel lift 3 ft (0.9 m)  
 - Automatic choke with vacuum pull-off  
 - Combustion air volume at rated load: 18.8 ft<sup>3</sup>/min (0.53 m<sup>3</sup>/min)  
 - (LPG) side-draft mixer with demand regulator  
 - Combustion air volume at rated load: 17.5 ft<sup>3</sup>/min (0.49 m<sup>3</sup>/min)  
 Ignition system: Electronic magneto type with resistor plugs  
 Starting system: Remote, 12 V, 3-wire, negative ground automotive type starter with steel pinion and ring gear, automatic start disconnect, connector for remote start cable, start-stop rocker switch mounted on set control  
 Lubrication: Full pressure positive displacement lube oil pump, spin-on, full flow lube oil filter, low oil pressure shutdown, dipstick  
 Oil capacity: 2.0 qt (1.9 L) including filter  
 Cylinder crankcase: Alloy aluminum with iron cylinder liners cast into the block, aluminum oil base  
 Cylinder head: Aluminum, OHV

#### Average fuel consumption:

Gasoline	No load	Half load	Full load
60 Hz	0.4 Gal/h (1.6 L/h)	0.7 Gal/h (2.8 L/h)	1.2 Gal/h (4.6 L/h)
LPG	No load	Half load	Full load
60 Hz	0.5 Gal/h (2.2 lb/h) 1.0 kg/h	0.8 Gal/h (3.5 lb/h) 1.8 kg/h	1.2 Gal/h (5.3 lb/h) 2.4 kg/h

#### Alternator details

Design: Cummins Onan revolving field, AC, 2-pole self-excited, two bearing design  
 Insulation system and temperature rise: Meets ANSI/RVIA EGS-1 and CSA Electrical Bulletin 946 requirements  
 Cooling: Direct drive centrifugal blower; cast aluminum housing for excellent heat transfer  
 Excitation: Digital voltage regulation  
 Rotor: Laminated electrical steel assembly press-fitted to shaft, balanced; heavy insulated copper wire windings; optimized air gap for improved waveform and motor starting  
 Stator: Laminated electrical steel assembly, skewed for improved waveform; heavy insulated copper wire windings  
 DC brushes: Electrographite; long life  
 Bearings: Double-sealed pre-lubricated ball bearings

#### Generator set performance

Air Conditioner Starting: Two 13500 Btu air conditioners with 3000 W base load at 100° F (38° C) at 500 ft (152.4) elevation  
 Frequency and voltage regulation: No load to full load, frequency <5%, voltage 1.1%

#### Basic dimensions

Dimensions: in(mm)

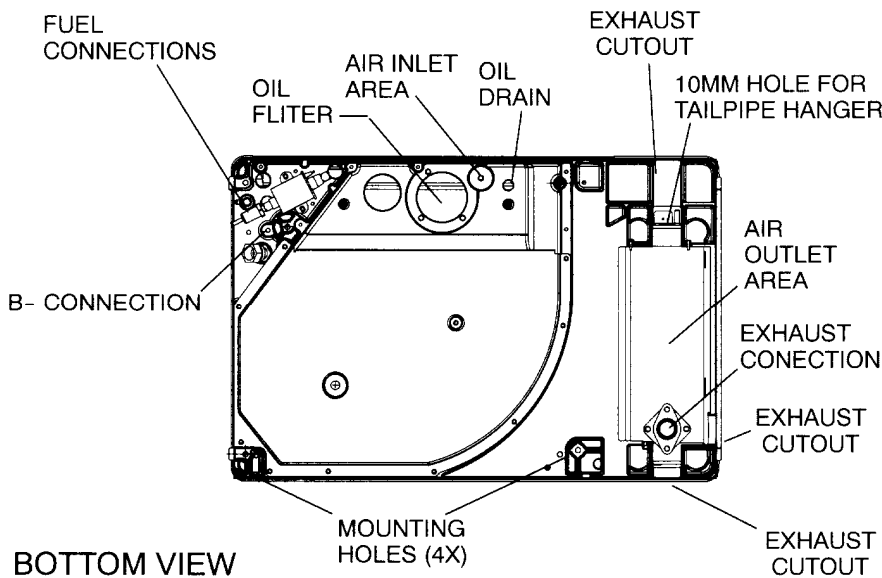
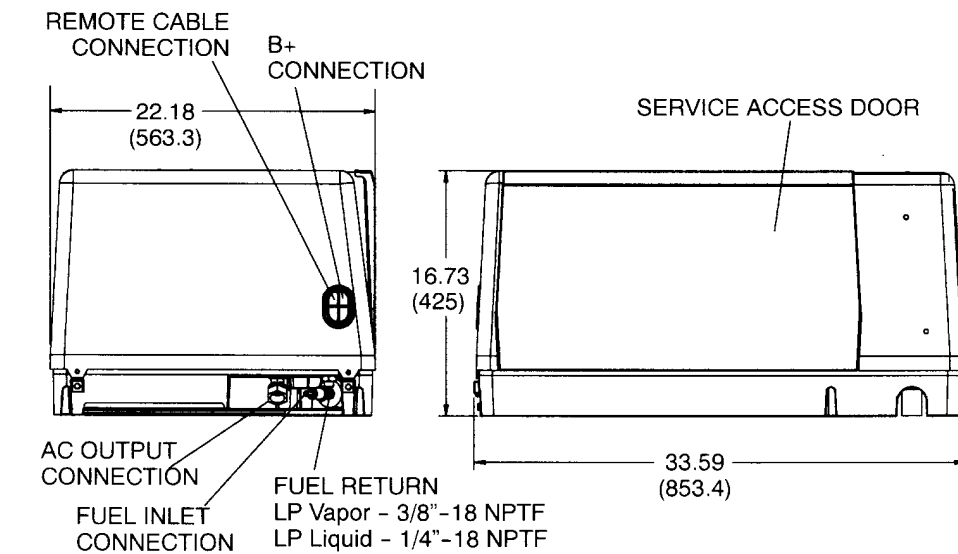

Note: This outline drawing is provided for general reference only and is not intended for design or installation. For more information see Operation and Installation manuals or obtain drawing 500-3234 and wiring diagram from your distributor/dealer.

## Accessories

- Remote start/stop rocker switch (P/N 300-5331)
- Remote control with start/stop switch and running time meter (P/N 300-5332)
- Remote control w/start/stop switch and DC voltmeter (P/N 300-5333)
- Remote control plug and wire harness: 10 ft (P/N 338-3489-01), 30 ft (P/N 338-3489-02)
- Battery, 12 V, 360 cold cranking amps at 0° F (-18° C)
- LPG vapor fuel conversion kit, (P/N 148-1161)
- Under floor mounting kit (P/N 405-6699)
- Installation template (P/N 539-2057)
- Tailpipe kit: 22 in (P/N 155-3481-01), 26 in (P/N 155-3481-02)
- Exhaust tube, straight with flanged end: 3 in (P/N 155-2610), (7 in - P/N 155-2424), 12.5 in (P/N 155-2610-01)
- Energy command auto generator start EC-30 (P/N 018-02030)
- Energy command remote start/stop with diagnostics EC-20 (P/N 018-02020)
- Energy command wireless start/stop EC-15W (P/N 018-02015)

## Testing for RV application

## After sale support

- Tested at extremes of temperature -20° F (-29° C) to 120° F (49° C) for starting and operation
- Tested with RV loads, air conditioners, microwaves, converter, TVs, VCRs
- Tested installed Cummins-owned RVs used for product development testing
- Tested in high humidity conditions
- Tested in salt spray conditions
- Tested in heavy airborne dust conditions
- Field test program
- 60 Hz (120 V only) models listed by SGS United States Testing Company, Inc. per ANSI/RVIA EGS-1 and CSA-certified per Electrical Bulletin 946
- This generator set was designed and manufactured in facilities certified to ISO 9001
- 60 Hz models meet applicable U.S. EPA and California emissions standards



## Warranty policy

This limited warranty covers virtually everything except routine maintenance for the first two years you own your RV generator set, and covers parts and labor on major power train and generator set parts during the third year. In addition, it also includes a free 90-day adjustment policy, which provides that Cummins Inc will make minor adjustments during the first three months you own it - free of charge! Please note: This 3-year limited warranty applies to RV generator sets used in RV applications only, and does not apply to RV generator sets used in commercial mobile applications.

The warranty period for the drive train belt and pulleys on the HGJ series generator sets used in recreational vehicles shall be the life of the generator set. For the original owner, this drive train warranty shall include parts and labor. For succeeding owners, this power train warranty shall cover belt and pulley parts only.

**⚠ WARNING:**

Do not use this generator set on a boat. Such use may violate U.S. Coast Guard regulations, and can result in severe personal injury or death from fire, explosion, electrocution, or carbon monoxide poisoning.

**⚠ WARNING:**

Back feed to a utility system can cause electrocution and/or property damage. Do not connect to any building electrical except through an approved device or after building main breaker is open.

Complete line of parts and accessories  
 Cummins Inc offers replacement and tune-up parts, accessories, oil and maintenance chemicals - all specially designed to help keep your Cummins Onan generator set running at peak performance. Cummins Inc. also provides genuine Onan Green Label Parts™ that exactly match generator set specifications and will help maximize power output and extend the life of your generator set.



Largest distributor/dealer support network  
 Cummins Onan generator sets are supported by the largest and best trained worldwide certified distributor/dealer network in the industry. This network of knowledgeable Cummins Onan distributor/dealers will help you select and install the right generator set and accessories to meet the requirements of your specific application. This same network offers a complete selection of commonly used generator set maintenance parts, accessories and products plus manuals and specification sheets. Plus, they can answer your questions regarding proper operation, maintenance schedules and more.

Manuals: Operation and installation manuals ship with the generator set. To obtain additional copies or other manuals for this model, see your Cummins Onan distributor/dealer and request the following manual numbers: Operation (983-0101B), Installation (983-0600B), Parts (983-0201D), Service (983-0501D).

To easily locate the nearest Cummins Onan distributor/dealer in your area, or for more information, contact us at 1-800-888-6626 (or 763-574-5000), or visit [www.cumminsonan.com](http://www.cumminsonan.com).

Contact your distributor/dealer for more information

# Cummins Onan

Cummins Power Generation  
 1400 73rd Ave. NE  
 Minneapolis, MN 55432 USA  
 Phone 1 763 574 5000  
 Toll-free 1 800 888 6626  
 Fax 1 763 574 5298  
 Email [www.cumminsonan.com/contact](http://www.cumminsonan.com/contact)  
[www.cumminsonan.com](http://www.cumminsonan.com)

